

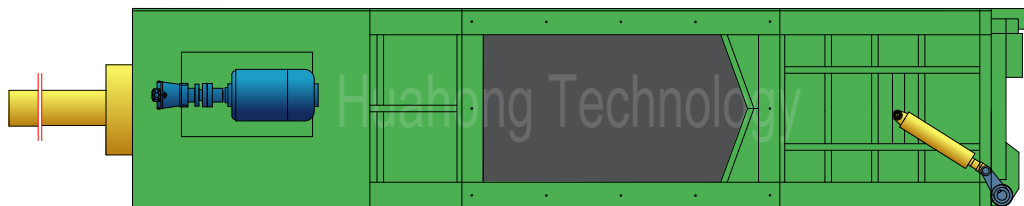

HPM250

Plan View

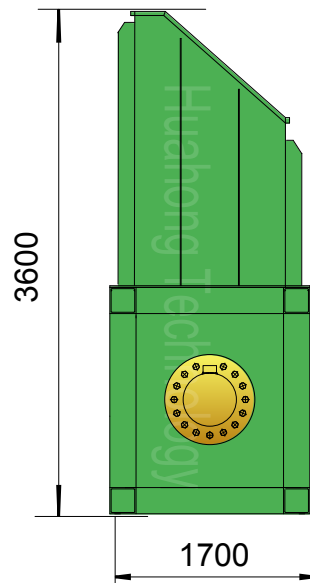

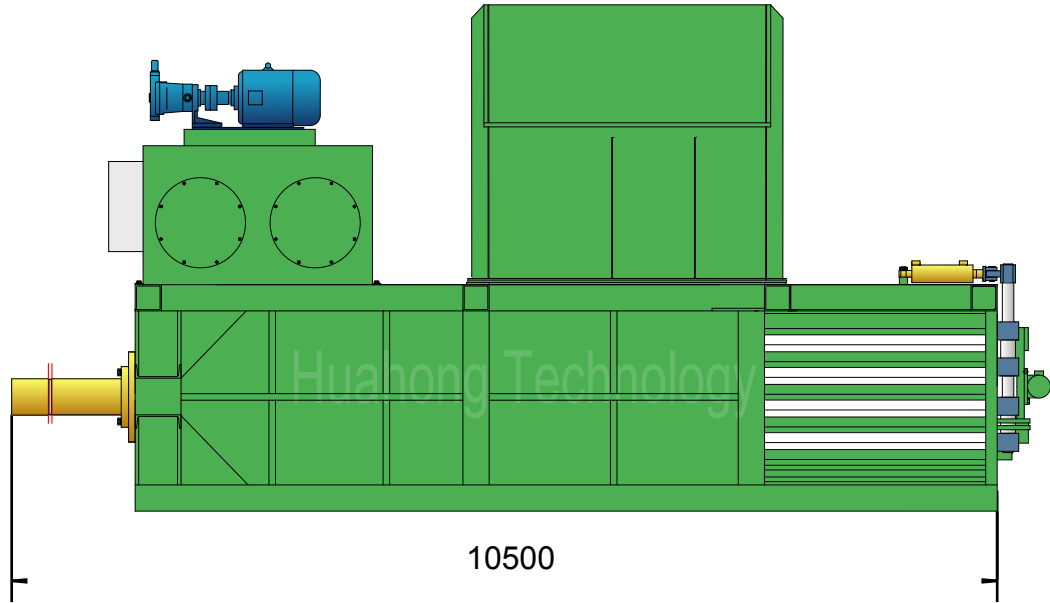

HPM250

Technical parameters

Horizontal Baler (Manual Belting)

Model: HPM250

Power System (Main Motor, 2 sets)

Type:	Y280S-6
Rated Power:	45 kW (/set)
Rated Speed:	980 rpm
Power Spec:	3PH, 50 / 60Hz

System Parameters

Main Pressure Cyl. Force:	250 Ton
Locking Cyl. Force:	30 Ton
Open-door Cyl. Force:	23.5 Ton
Hydraulic System Pressure:	25 MPa

Hydraulic System (Pump, 3 sets)

Pump #1, #2:	250YCY14-1B
Rated Displacement:	250 ml/r (/set)
Max Operating Pressure:	31.5 MPa

Standard Configuration

V-shaped Cutting Blades; Oil Cooler;
Conveyor Width 1600mm, Powered by 7.5kW Motor;
Discharging Roll Powered by 0.75kW Motor.

Pump #3:	25YCY14-1B
Rated Displacement:	25 ml/r
Max Operating Pressure:	31.5 MPa

Optional Configuration

NOK (JAPAN) Seal Packings for Cylinders;
Oil Heater; Magnetic Oil Filter;
Diesel / Diesel Generator for Power.

Operation System

PLC Operation

General Description

Main Machine Size (L×W×H):	10500×1700×3600 mm
Feeding Opening (L×W):	2200×1120 mm
Bale Size (W×H):	1120×1300 mm
Bale Weight (Cardboard):	1050-1500 kg
Production Rate (Cardboard):	6.3-9.5 tons/hr
Strapping:	Tempered Iron Wire, φ3.6/4.0mm, 7 Lines, Manual Strapping.
Shipping Weight:	Approx. 21 + 7 tons
Loading (Standard Containers):	2×40'GP

Hydraulic Oil Brand

Oil Tank Volume: 3200 ltr

ISO VG	China	U.S.		Britain	France
	GB11118.1	CALTEX CO.	MOBIL	SHELL	ELF CO.
HM 46	46 #	Rando HD46	D.T.E46	Tellus 46	Elfolna 46
HM 68	68 #	Rando HD68	D.T.E68	Tellus 68	Elfolna 68

Above information are indicative not engaging. Rights reserved for change if necessary.