

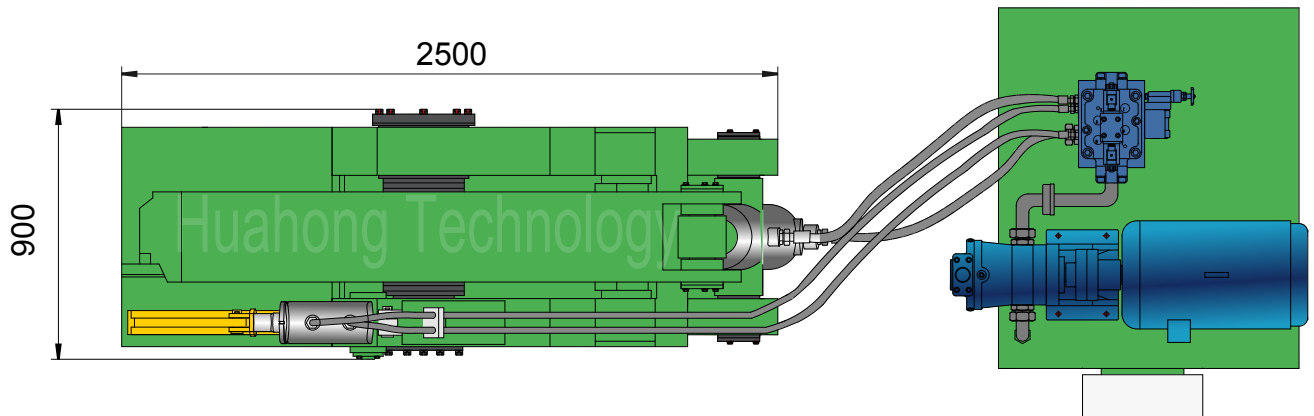

# Q43-1600B

## Plan View

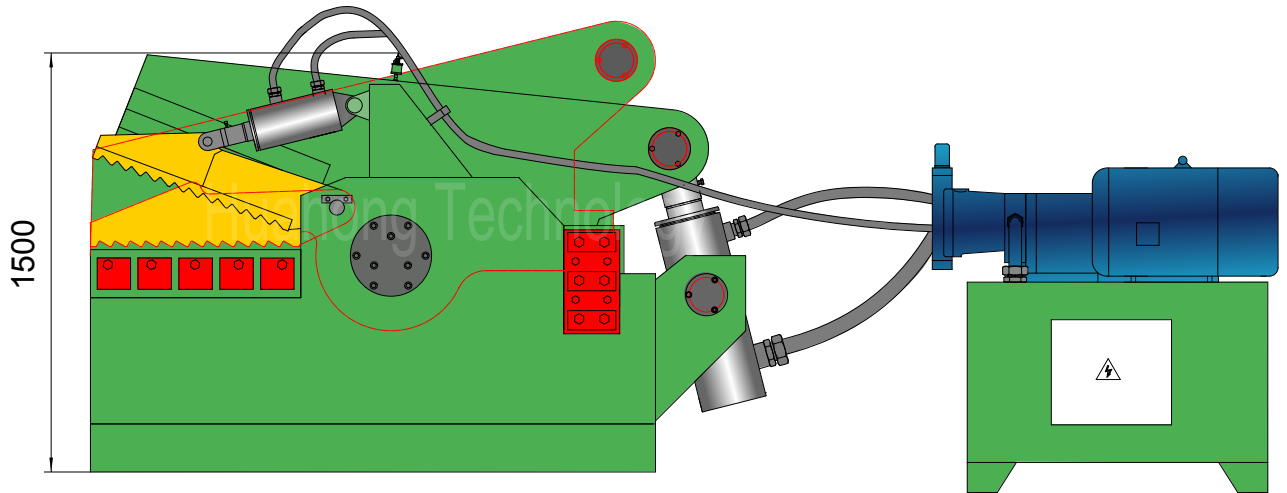



# Q43-1600B

## Technical parameters

### Hydraulic Shear (Alligator Type)

Model: Q43-1600B

### Power System (Motor)

Type: Y180M-4  
 Rated Power: 18.5 kW  
 Rated Speed: 1470 rpm  
 Power Spec: 3PH, 50 / 60Hz

### Hydraulic System (Pump)

Type: 80YCY14-1B  
 Rated Displacement: 80 ml/r  
 Max Operating Pressure: 31.5 MPa

### Operation System

Hydro-electrical Valves, Push Button Control.

### System Parameters

Max. Shearing Force: 160 Ton  
 Max. Pressing Force: 20 Ton  
 Hydraulic System Pressure: 25 MPa  
 Cutting Speed: 6-10 times/min

### Max. Cutting Size

Angle Steel: 120×120×10 mm (3 PCS)  
 Channel Steel: 200×75×9 mm  
 Steel Sheet: 25×200 mm  
 Square Billet: 45×45 mm  
 Round Steel Bar: φ50 mm

### Optional Configuration

NOK (JAPAN) Seal Packings for Cylinders;  
 Cooler / Heater; Magnetic Oil Filter;  
 Safety Caging;  
 Diesel / Diesel Generator for Power.

### General Description

Main Machine Size (L×W×H): 2500×900×1500 mm  
 Blade Length: 800 mm  
 Max. Blade Opening: 320 mm  
 Shipping Weight: Approx. 4.2 tons  
 Loading (Standard Containers): 1/2×20'GP

### Hydraulic Oil Brand

Oil Tank Volume: 600 ltr

ISO VG	China	U.S.		Britain	France
	GB11118.1	CALTEX CO.	MOBIL	SHELL	ELF CO.
HM 46	46 #	Rando HD46	D.T.E46	Tellus 46	Elfolna 46
HM 68	68 #	Rando HD68	D.T.E68	Tellus 68	Elfolna 68

Above information are indicative not engaging. Rights reserved for change if necessary.