

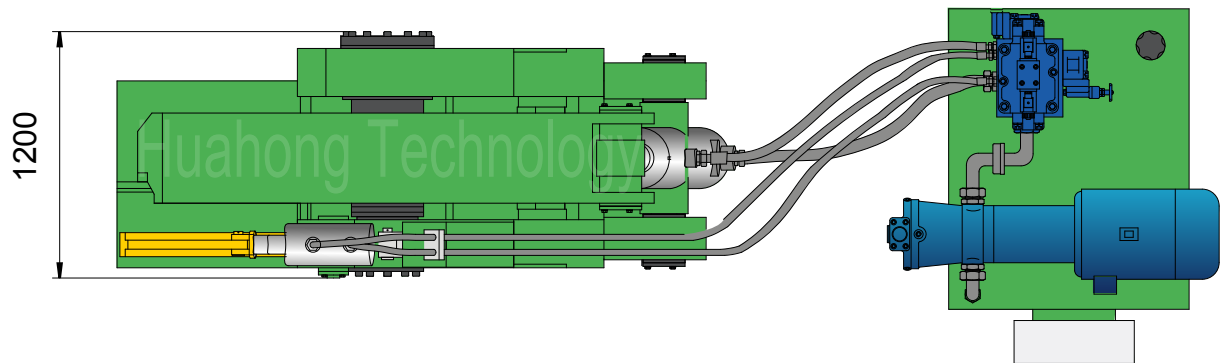

Q43-3150A

Plan View

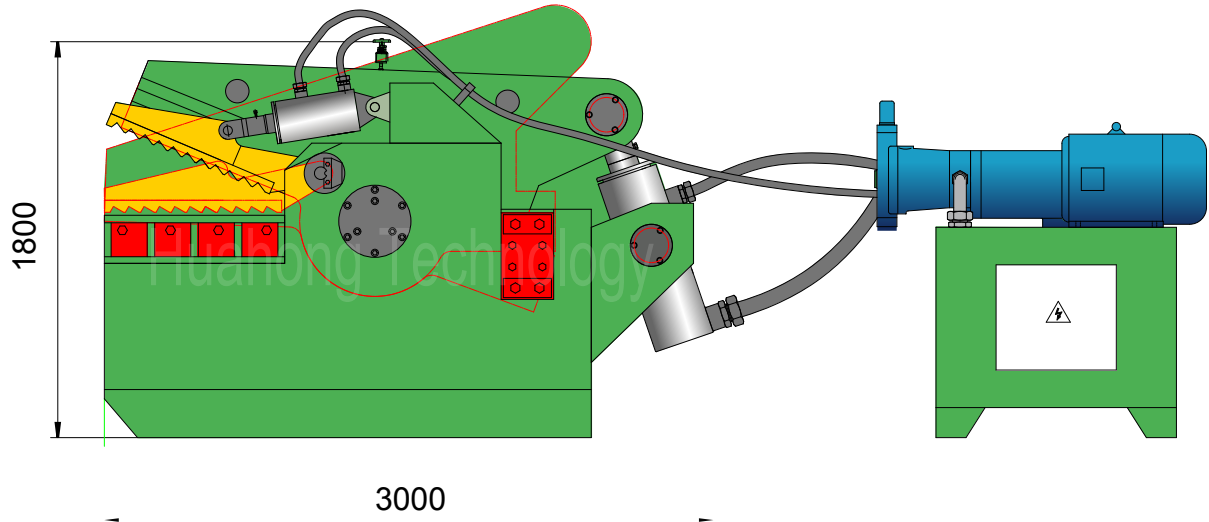



Q43-3150A

Technical parameters

Hydraulic Shear (Alligator Type)

Model: Q43-3150A

Power System (Motor, 2 sets)

Type: Y180M-4
 Rated Power: 18.5 kW (/set)
 Rated Speed: 1470 rpm
 Power Spec: 3PH, 50 / 60Hz

Hydraulic System (Pump, 2 sets)

Type: 80YCY14-1B
 Rated Displacement: 80 ml/r (/set)
 Max Operating Pressure: 31.5 MPa

Operation System

Hydro-electrical Valves, Push Button Control.

System Parameters

Max. Shearing Force: 315 Ton
 Max. Pressing Force: 26 Ton
 Hydraulic System Pressure: 25 MPa
 Cutting Speed: 6-8 times/min

Max. Cutting Size

Angle Steel: 160×160×12 mm (3 PCS)
 I-beam: 250×118×10 mm
 Channel Steel: 280×124×11.5 mm
 Steel Sheet: 20×700 / 40×300 mm
 Square Billet: 70×70 mm
 Round Steel Bar: φ80 mm

Optional Configuration

NOK (JAPAN) Seal Packings for Cylinders;
 Cooler / Heater; Magnetic Oil Filter;
 Safety Caging;
 Diesel / Diesel Generator for Power.

General Description

Main Machine Size (L×W×H): 3000×1200×1800 mm
 Blade Length: 1000 mm
 Max. Blade Opening: 460 mm
 Shipping Weight: Approx. 9 tons
 Loading (Standard Containers): 1×20'GP

Hydraulic Oil Brand

Oil Tank Volume: 1400 ltr

ISO VG	China	U.S.		Britain	France
	GB11118.1	CALTEX CO.	MOBIL	SHELL	ELF CO.
HM 46	46 #	Rando HD46	D.T.E46	Tellus 46	Elfolna 46
HM 68	68 #	Rando HD68	D.T.E68	Tellus 68	Elfolna 68

Above information are indicative not engaging. Rights reserved for change if necessary.