

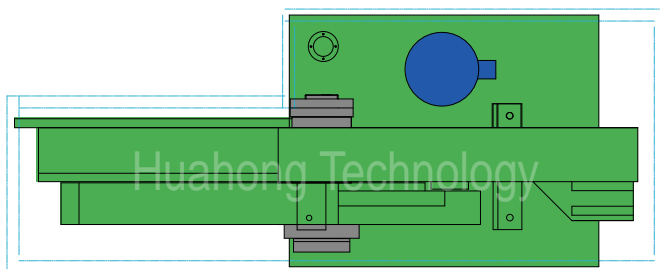

QE43-800

Plan View

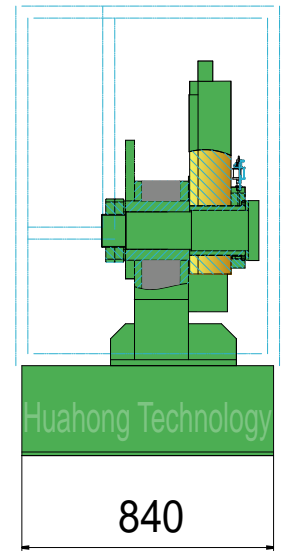

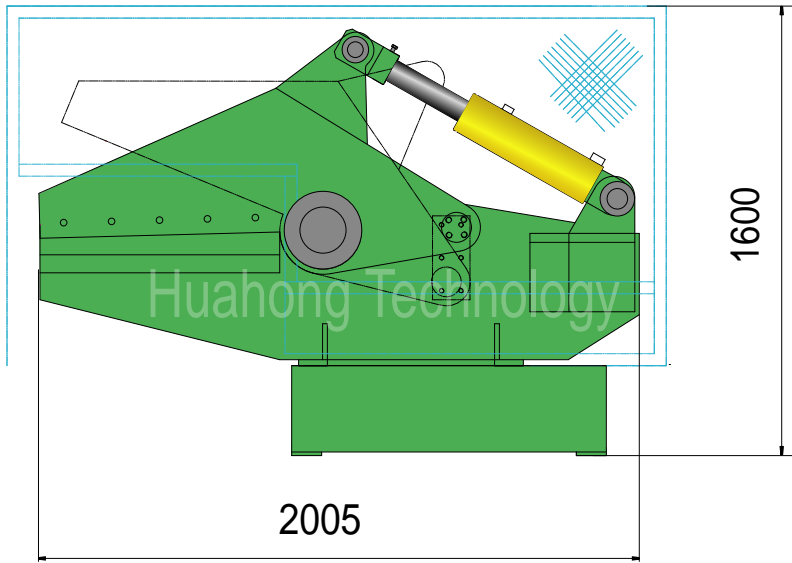

QE43-800

Technical parameters

Hydraulic Shear (Alligator Type)

Model: QE43-800

Power System (Motor)

Type: 10P-V524-V23
 Rated Power: 7.5 kW
 Rated Speed: 1740 rpm
 Power Spec: 3PH, 50 / 60Hz

Hydraulic System (Pump)

Type: V23A4R
 Rated Displacement: 23 ml/r
 Max Operating Pressure: 25 MPa

Operation System

Pedal Valve Operation

System Parameters

Max. Shearing Force: 80 Ton
 Hydraulic System Pressure: 13 MPa
 Cutting Speed: 8-12 times/min

Max. Cutting Size

Angle Steel: 40×40×4 mm (3 PCS)
 Steel Sheet: 14×125 mm
 Square Billet: 30×30 mm
 Round Steel Bar: φ35 mm

Standard Configuration

NOK (JAPAN) Seal Packings for Cylinders;
 Safety Caging.

General Description

Main Machine Size (L×W×H): 2200×900×1600 mm
 Blade Length: 800 mm
 Max. Blade Opening: 340 mm
 Shipping Weight: Approx. 1.8 tons
 Loading (Standard Containers): 1/6×20'GP

Hydraulic Oil Brand

Oil Tank Volume: 250 ltr

ISO VG	China	U.S.		Britain	France
	GB11118.1	CALTEX CO.	MOBIL	SHELL	ELF CO.
HM 46	46 #	Rando HD46	D.T.E46	Tellus 46	Elfolna 46
HM 68	68 #	Rando HD68	D.T.E68	Tellus 68	Elfolna 68

Above information are indicative not engaging. Rights reserved for change if necessary.