

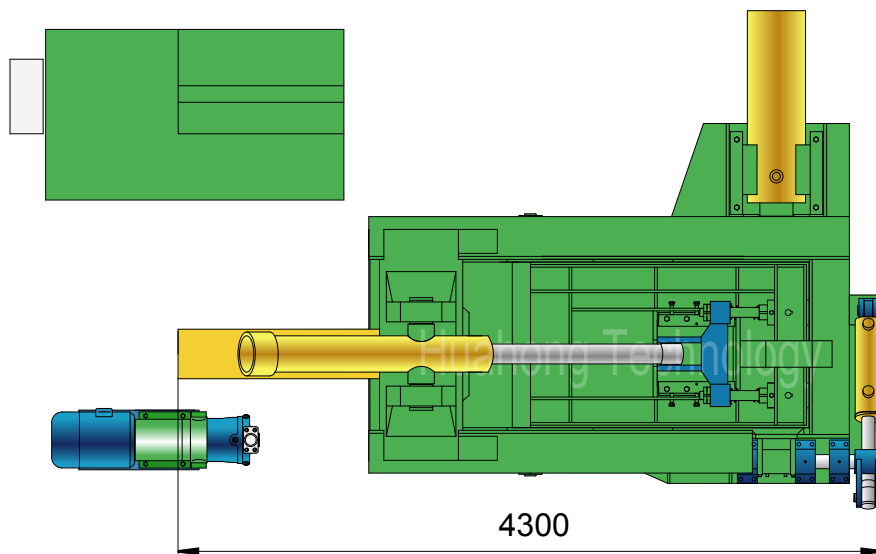

# Y81F-160A

## Plan View

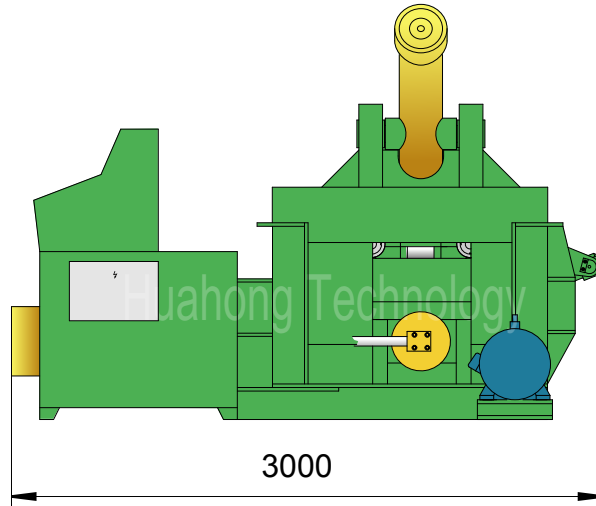

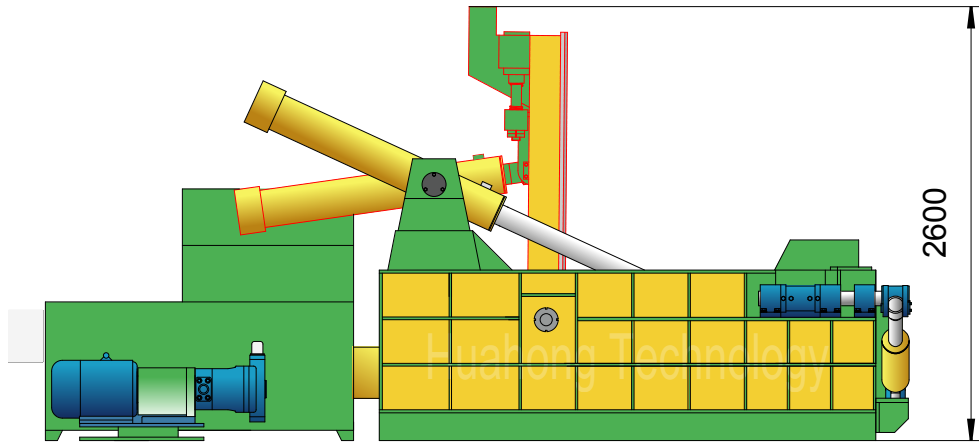

# Y81F-160A

## Technical parameters

### "Turn-out" Type Metal Baler

Model: Y81F-160A

#### Power System (Motor)

Type: Y200L2-6  
 Rated Power: 22 kW  
 Rated Speed: 970 rpm  
 Power Spec: 3PH, 50 / 60Hz

#### Hydraulic System (Pump)

Type: 160YCY14-1B  
 Rated Displacement: 160 ml/r  
 Max Operating Pressure: 31.5 MPa

#### Standard Configuration

A3 Steel Liners, Surface Heat Treatment.

#### System Parameters

Lid Cyl. Force: 63 Ton  
 Side Pressure Cyl. Force: 125 Ton  
 Main Pressure Cyl. Force: 160 Ton  
 Bale Discharge Cyl. Force: 10 Ton  
 Hydraulic System Pressure: 25 MPa  
 Idle Cycle Time: Approx. 100 Sec

#### Operation System

Manual Valve Operation

#### Optional Configuration

Cutting Blades & Teeth (2 sides);  
 Cooler / Heater;  
 Diesel / Diesel Generator for Power.

#### General Description

Main Machine Size (L×W×H): 4300×3000×2600 mm  
 Press Box Size (L×W×H): 1600×1000×800 mm  
 Bale Size (W×H): 350×350 / 400×400 / Octagon 400 mm  
 Bale Weight (Steel): 100-180 kg  
 Production Rate (Steel): 2.0-3.5 tons/hr  
 Shipping Weight: Approx. 10.5 tons  
 Loading (Standard Containers):

#### Hydraulic Oil Brand

Oil Tank Volume: 1200 ltr

ISO VG	China	U.S.		Britain	France
	GB11118.1	CALTEX CO.	MOBIL	SHELL	ELF CO.
HM 46	46 #	Rando HD46	D.T.E46	Tellus 46	Elfolna 46
HM 68	68 #	Rando HD68	D.T.E68	Tellus 68	Elfolna 68

Above information are indicative not engaging. Rights reserved for change if necessary.