

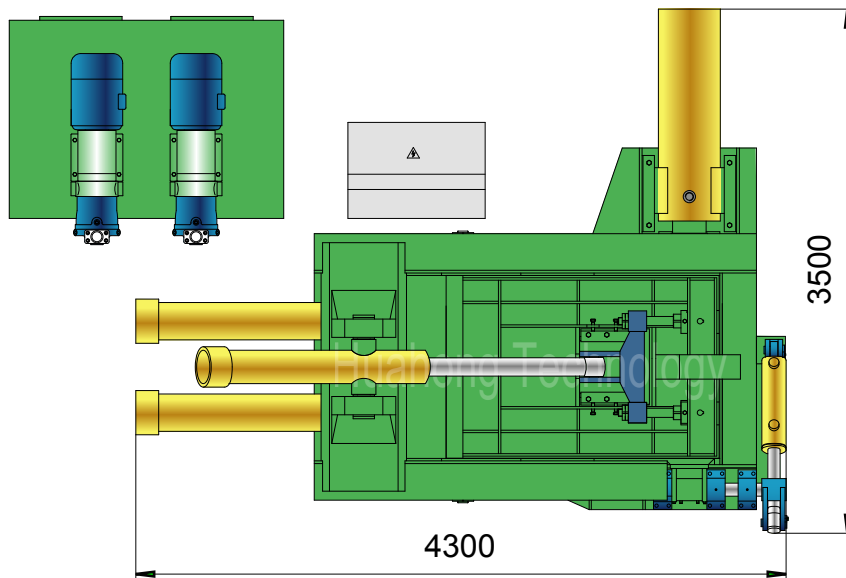

Y81F-160B

Plan View

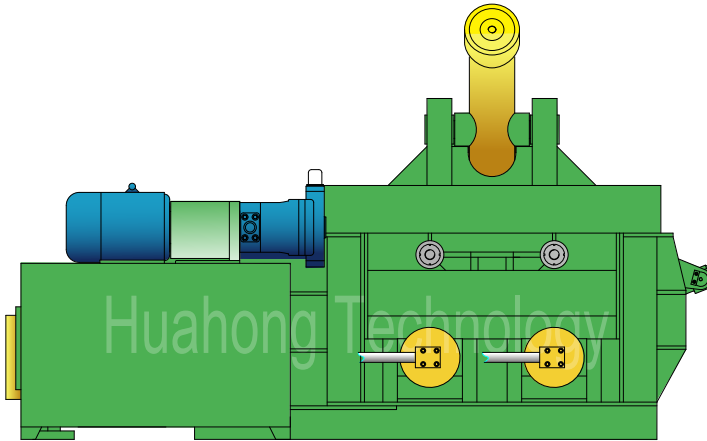

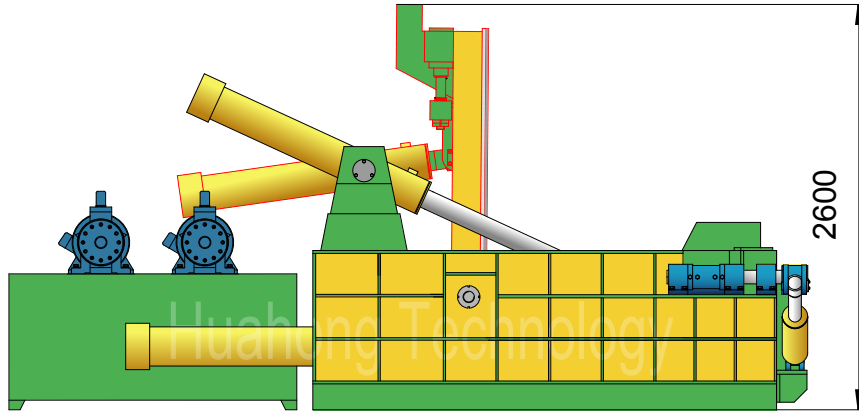

Y81F-160B

Technical parameters

"Turn-out" Type Metal Baler

Model: Y81F-160B

Power System (Motor, 2 sets)

Type: Y180M-4
 Rated Power: 18.5 kW (/set)
 Rated Speed: 1470 rpm
 Power Spec: 3PH, 50 / 60Hz

Hydraulic System (Pump, 2 sets)

Type: 80YCY14-1B
 Rated Displacement: 80 ml/r (/set)
 Max Operating Pressure: 31.5 MPa

Standard Configuration

A3 Steel Liners, Surface Heat Treatment.

System Parameters

Lid Cyl. Force: 63 Ton
 Side Pressure Cyl. Force: 2×80 Ton
 Main Pressure Cyl. Force: 160 Ton
 Bale Discharge Cyl. Force: 10 Ton
 Hydraulic System Pressure: 25 MPa
 Idle Cycle Time: Approx. 80 Sec

Operation System

Manual Valve Operation

Optional Configuration

Cutting Blades & Teeth (2 sides);
 Cooler / Heater;
 Diesel / Diesel Generator for Power.

General Description

Main Machine Size (L×W×H): 4300×3500×2600 mm
 Press Box Size (L×W×H): 1600×1200×800 mm
 Bale Size (W×H): 400×400 / Octagon 400 mm
 Bale Weight (Steel): 100-200 kg
 Production Rate (Steel): 2.0-4.0 tons/hr
 Shipping Weight: Approx. 13.5 tons
 Loading (Standard Containers):

Hydraulic Oil Brand

Oil Tank Volume: 1400 ltr

| ISO VG | China | U.S. | | Britain | France |
|--------|-----------|------------|---------|-----------|------------|
| | GB11118.1 | CALTEX CO. | MOBIL | SHELL | ELF CO. |
| HM 46 | 46 # | Rando HD46 | D.T.E46 | Tellus 46 | Elfolna 46 |
| HM 68 | 68 # | Rando HD68 | D.T.E68 | Tellus 68 | Elfolna 68 |

Above information are indicative not engaging. Rights reserved for change if necessary.