

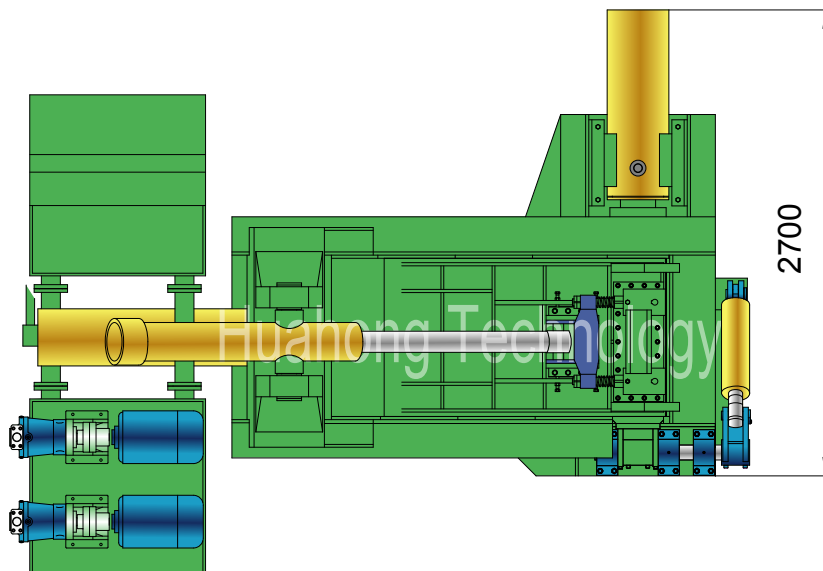

# Y81F-160C

## Plan View

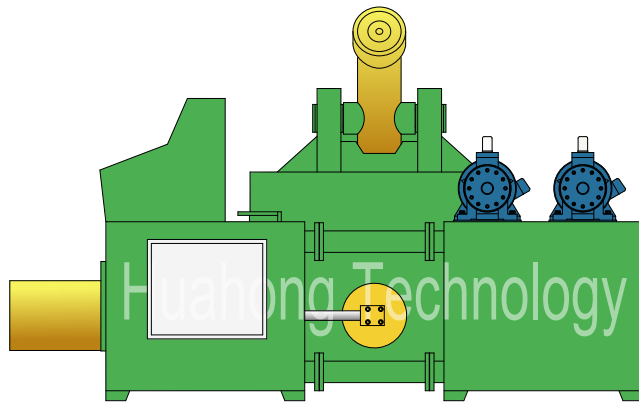

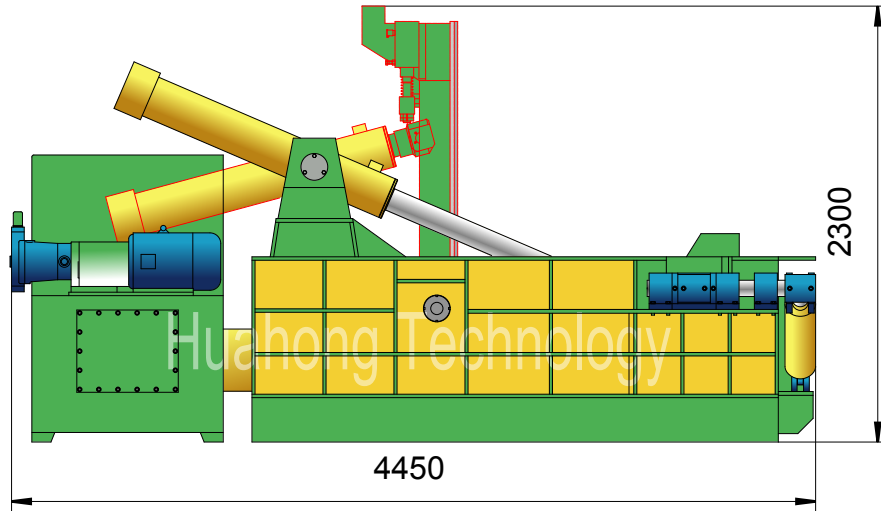

# Y81F-160C

## Technical parameters

### "Turn-out" Type Metal Baler

Model: Y81F-160C

#### Power System (Motor, 2 sets)

Type: Y160L-4  
 Rated Power: 15 kW (/set)  
 Rated Speed: 1460 rpm  
 Power Spec: 3PH, 50 / 60Hz

#### Hydraulic System (Pump, 2 sets)

Type: 63YCY14-1B  
 Rated Displacement: 63 ml/r (/set)  
 Max Operating Pressure: 31.5 MPa

#### Standard Configuration

A3 Steel Liners, Surface Heat Treatment.

#### System Parameters

Lid Cyl. Force: 63 Ton  
 Side Pressure Cyl. Force: 125 Ton  
 Main Pressure Cyl. Force: 160 Ton  
 Bale Discharge Cyl. Force: 10 Ton  
 Hydraulic System Pressure: 25 MPa  
 Idle Cycle Time: Approx. 80 Sec

#### Operation System

Manual Valve Operation

#### Optional Configuration

Cutting Blades & Teeth (2 sides);  
 Cooler / Heater;  
 Diesel / Diesel Generator for Power.

#### General Description

Main Machine Size (L×W×H): 4450×2700×2300 mm  
 Press Box Size (L×W×H): 1400×900×700 mm  
 Bale Size (W×H): 320×320 mm  
 Bale Weight (Steel): 80-130 kg  
 Production Rate (Steel): 2.0-3.0 tons/hr  
 Shipping Weight: Approx. 10.2 tons  
 Loading (Standard Containers):

#### Hydraulic Oil Brand

Oil Tank Volume: 1600 ltr

| ISO VG | China     | U.S.       |         | Britain   | France     |
|--------|-----------|------------|---------|-----------|------------|
|        | GB11118.1 | CALTEX CO. | MOBIL   | SHELL     | ELF CO.    |
| HM 46  | 46 #      | Rando HD46 | D.T.E46 | Tellus 46 | Elfolna 46 |
| HM 68  | 68 #      | Rando HD68 | D.T.E68 | Tellus 68 | Elfolna 68 |

Above information are indicative not engaging. Rights reserved for change if necessary.