

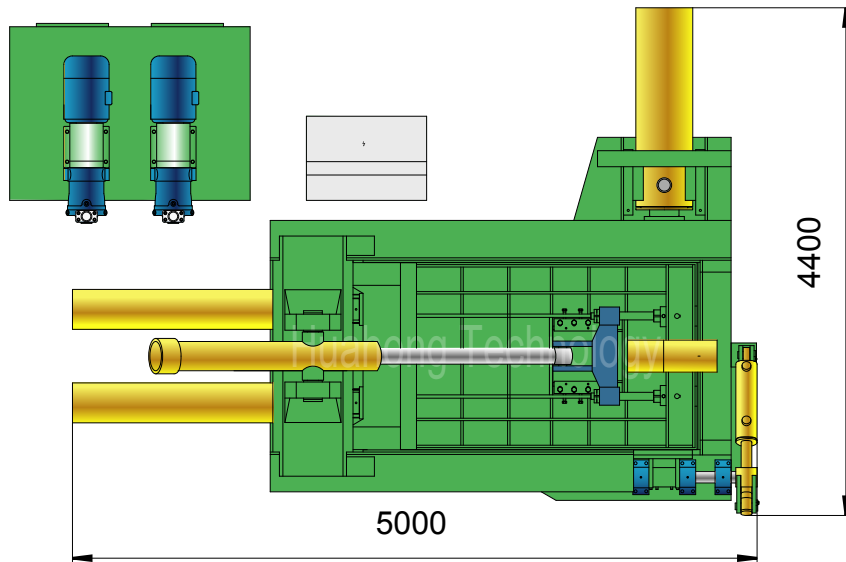

Y81F-250G

Plan View

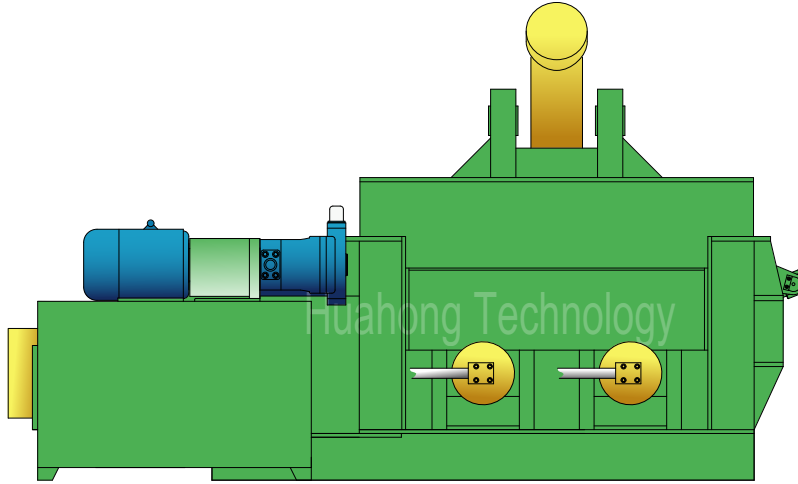

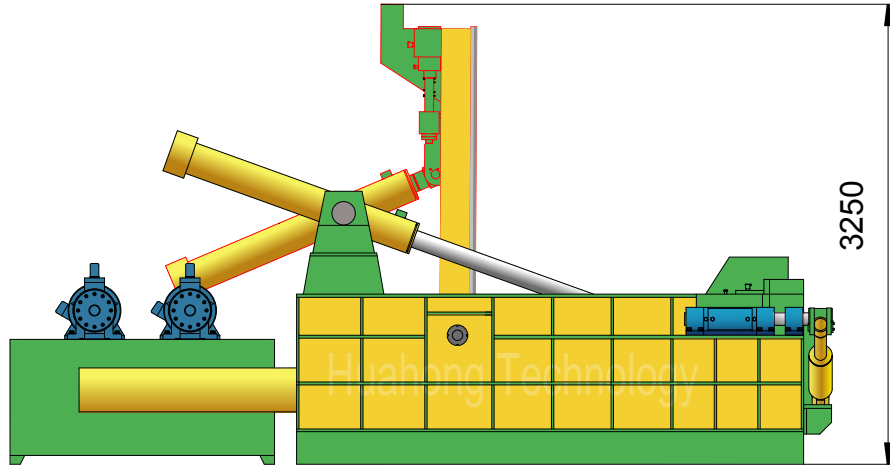

Y81F-250G

Technical parameters

"Turn-out" Type Metal Baler

Model: Y81F-250G

Power System (Motor, 2 sets)

Type: Y225M-6
 Rated Power: 30 kW (/set)
 Rated Speed: 980 rpm
 Power Spec: 3PH, 50 / 60Hz

System Parameters

Lid Cyl. Force: 100 Ton
 Side Pressure Cyl. Force: 2×120 Ton
 Main Pressure Cyl. Force: 250 Ton
 Bale Discharge Cyl. Force: 8 Ton
 Hydraulic System Pressure: 25 MPa
 Idle Cycle Time: Approx. 130 Sec

Hydraulic System (Pump, 2 sets)

Type: 160YCY14-1B
 Rated Displacement: 160 ml/r (/set)
 Max Operating Pressure: 31.5 MPa

Operation System

Manual Valve Operation

Standard Configuration

A3 Steel Liners, Surface Heat Treatment.

Optional Configuration

Cutting Blades & Teeth (2 sides);
 Cooler / Heater;
 Diesel / Diesel Generator for Power.

General Description

Main Machine Size (L×W×H): 5000×4400×3250 mm
 Press Box Size (L×W×H): 2000×1750×1200 mm
 Bale Size (W×H): 600×600 mm
 Bale Weight (Steel): 300-500 kg
 Production Rate (Steel): 5.0-8.0 tons/hr
 Shipping Weight: Approx. 24.5 tons
 Loading (Standard Containers):

Hydraulic Oil Brand

Oil Tank Volume: 2800 ltr

ISO VG	China	U.S.		Britain	France
	GB11118.1	CALTEX CO.	MOBIL	SHELL	ELF CO.
HM 46	46 #	Rando HD46	D.T.E46	Tellus 46	Elfolna 46
HM 68	68 #	Rando HD68	D.T.E68	Tellus 68	Elfolna 68

Above information are indicative not engaging. Rights reserved for change if necessary.