

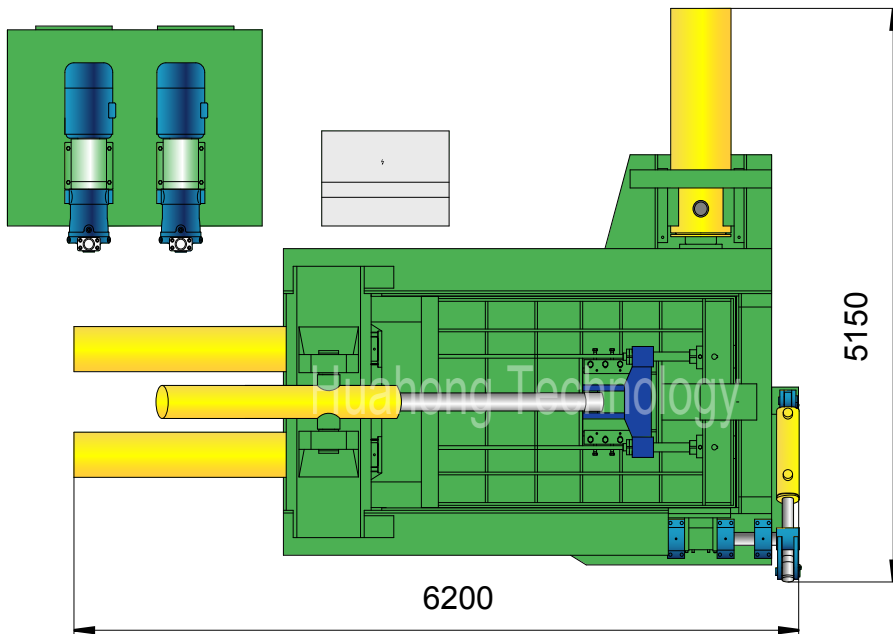

Y81F-315E

Plan View

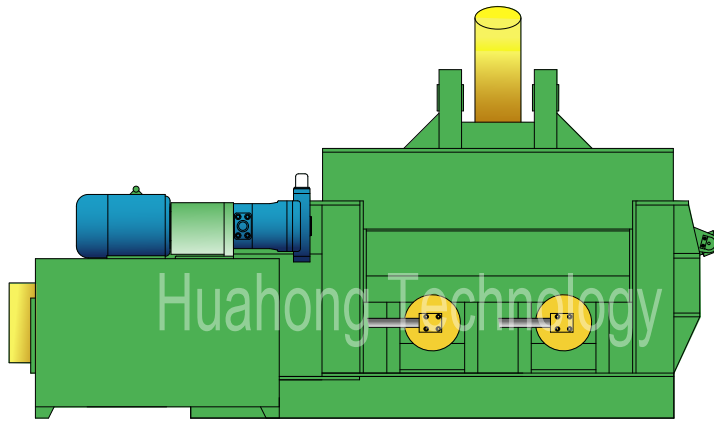

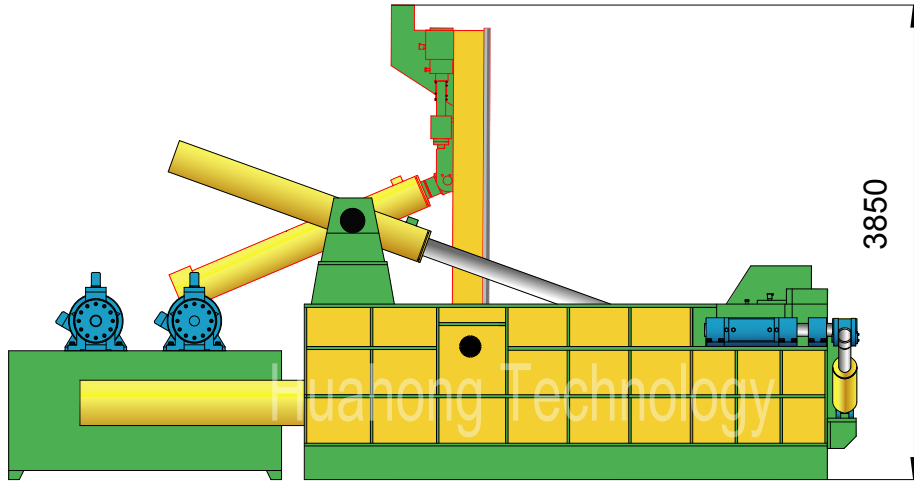

Y81F-315E

Technical parameters

"Turn-out" Type Metal Baler

Model: Y81F-315E

Power System (Motor, 2 sets)

Type:	Y280S-6
Rated Power:	45 kW (/set)
Rated Speed:	980 rpm
Power Spec:	3PH, 50 / 60Hz

Hydraulic System (Pump, 2 sets)

Type:	250YCY14-1B
Rated Displacement:	250 ml/r (/set)
Max Operating Pressure:	31.5 MPa

Standard Configuration

A3 Steel Liners, Surface Heat Treatment.

System Parameters

Lid Cyl. Force:	120 Ton
Side Pressure Cyl. Force:	2×160 Ton
Main Pressure Cyl. Force:	315 Ton
Bale Discharge Cyl. Force:	10 Ton
Hydraulic System Pressure:	25 MPa
Idle Cycle Time:	Approx. 180 Sec

Operation System

Manual Valve Operation

Optional Configuration

Cutting Blades & Teeth (2 sides);
Cooler / Heater;
Diesel / Diesel Generator for Power.

General Description

Main Machine Size (L×W×H):	6200×5150×3850 mm
Press Box Size (L×W×H):	2500×2000×1200 mm
Bale Size (W×H):	600×600 mm
Bale Weight (Steel):	400-700 kg
Production Rate (Steel):	6.0-10.0 tons/hr
Shipping Weight:	Approx. 39 tons
Loading (Standard Containers):	

Hydraulic Oil Brand

Oil Tank Volume: 2800 ltr

ISO VG	China	U.S.		Britain	France
	GB11118.1	CALTEX CO.	MOBIL	SHELL	ELF CO.
HM 46	46 #	Rando HD46	D.T.E46	Tellus 46	Elfolna 46
HM 68	68 #	Rando HD68	D.T.E68	Tellus 68	Elfolna 68

Above information are indicative not engaging. Rights reserved for change if necessary.