

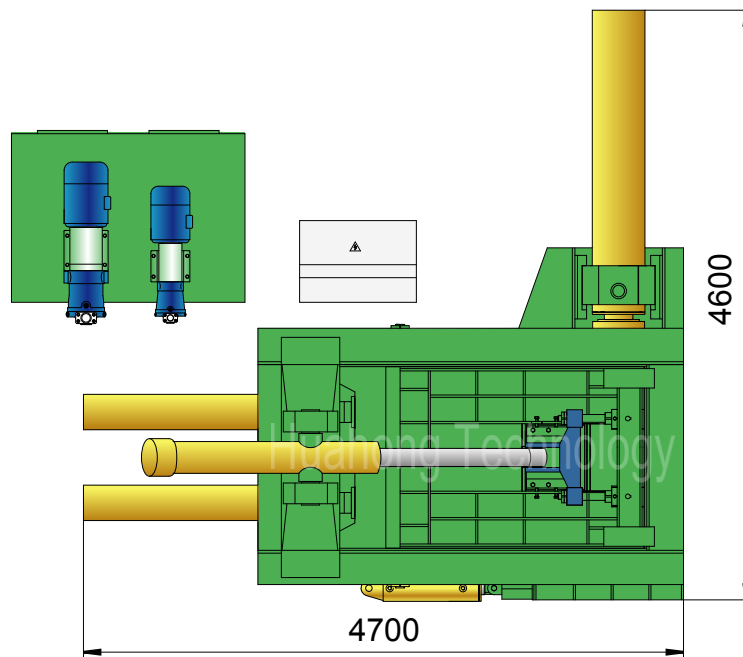

Y81T-200C

Plan View

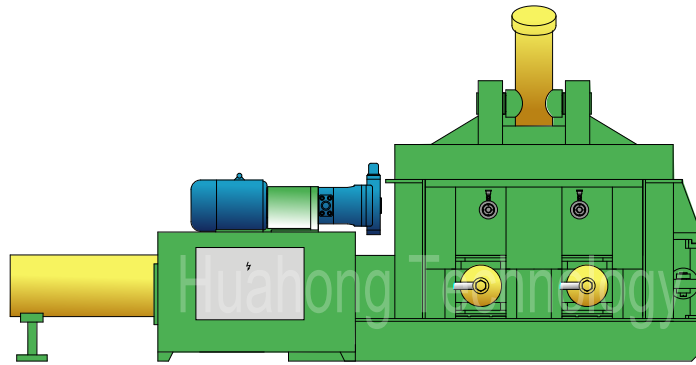

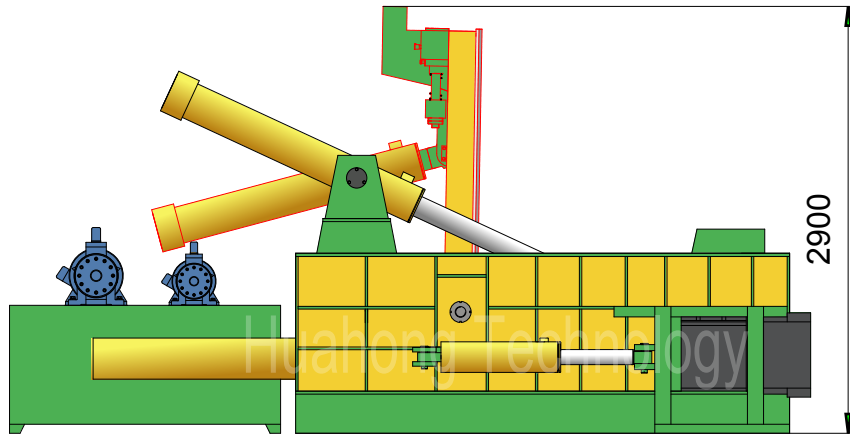

Y81T-200C

Technical parameters

"Push-out" Type Metal Baler

Model: Y81T-200C

Power System (Motor, 2 sets)

Type: Y200L2-6
 Rated Power: 22 kW (/set)
 Rated Speed: 970 rpm
 Power Spec: 3PH, 50 / 60Hz

Hydraulic System (Pump, 2 sets)

Type: 160YCY14-1B
 Rated Displacement: 160 ml/r (/set)
 Max Operating Pressure: 31.5 MPa

Operation System (Optional)

Option 1: Manual Valve Operation
 Option 2: PLC Operation

System Parameters

Lid Cyl. Force: 80 Ton
 Side Pressure Cyl. Force: 2×100 Ton
 Main Pressure Cyl. Force: 200 Ton
 Small Door Cyl. Force: 50 Ton
 Hydraulic System Pressure: 25 MPa
 Idle Cycle Time: Approx. 110 Sec

Standard Configuration

A3 Steel Liners, Surface Heat Treatment.

Optional Configuration

Cutting Blades & Teeth (2 sides);
 Loading Hopper; Cooler / Heater;
 Diesel / Diesel Generator for Power.

General Description

Main Machine Size (L×W×H): 4700×4600×2900 mm
 Press Box Size (L×W×H): 1800×1400×900 mm
 Bale Size (W×H): 500×500 mm
 Bale Weight (Steel): 180-350 kg
 Production Rate (Steel): 3.5-6.0 tons/hr
 Shipping Weight: Approx. 18.8 tons
 Loading (Standard Containers):

Hydraulic Oil Brand

Oil Tank Volume: 2300 ltr

ISO VG	China	U.S.		Britain	France
	GB11118.1	CALTEX CO.	MOBIL	SHELL	ELF CO.
HM 46	46 #	Rando HD46	D.T.E46	Tellus 46	Elfolna 46
HM 68	68 #	Rando HD68	D.T.E68	Tellus 68	Elfolna 68

Above information are indicative not engaging. Rights reserved for change if necessary.