

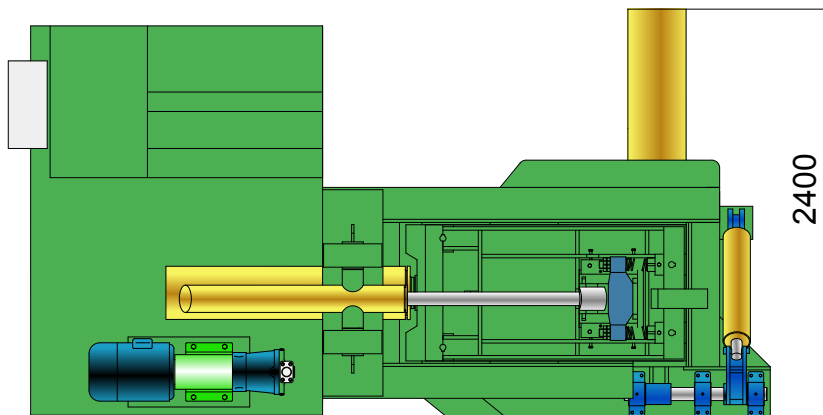

YE81F-125G

Plan View

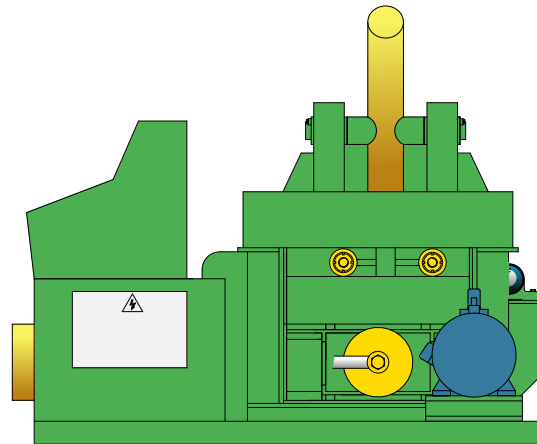

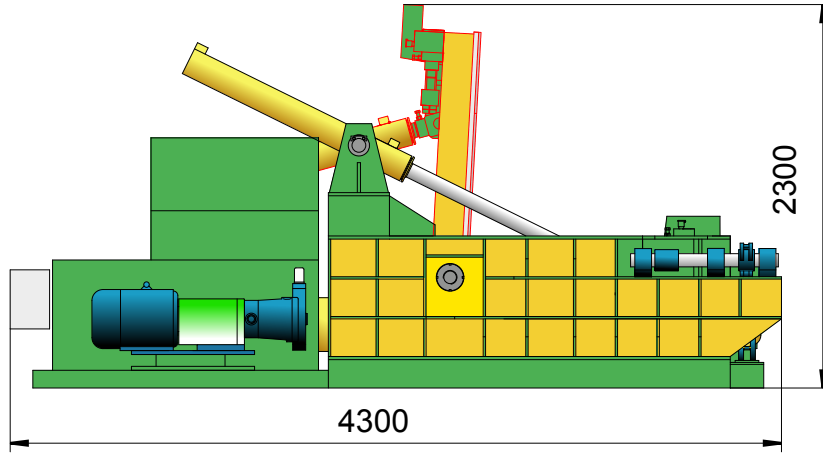

YE81F-125G

Technical parameters

"Turn-out" Type Metal Baler

Model: YE81F-125G

Power System (Motor)

Type: Y200L2-6
 Rated Power: 22 kW
 Rated Speed: 970 rpm
 Power Spec: 3PH, 50 / 60Hz

System Parameters

Lid Cyl. Force: 50 Ton
 Side Pressure Cyl. Force: 100 Ton
 Main Pressure Cyl. Force: 125 Ton
 Bale Discharge Cyl. Force: 8 Ton
 Hydraulic System Pressure: 25 MPa
 Idle Cycle Time: Approx. 80 Sec

Hydraulic System (Pump)

Type: 160YCY14-1B
 Rated Displacement: 160 ml/r
 Max Operating Pressure: 31.5 MPa

Operation System

Manual Valve Operation

Standard Configuration

#45 Steel Liners 18mm, Wholly Heat Treated;
 NOK (JAPAN) Seal Packings for Cylinders;
 Cooler / Heater; Magnetic Oil Filter.

Optional Configuration

Cutting Blades & Teeth (2 sides);
 Mn65 Steel Liners for High Pressure Chamber;
 Diesel / Diesel Generator for Power.

General Description

Main Machine Size (L×W×H): 4300×2400×2300 mm
 Press Box Size (L×W×H): 1400×700×700 mm
 Bale Size (W×H): 300×300 mm
 Bale Weight (Steel): 60-90 kg
 Production Rate (Steel): 1.5-2.0 tons/hr
 Shipping Weight: Approx. 7.5 tons
 Loading (Standard Containers): 1×20'GP

Hydraulic Oil Brand

Oil Tank Volume: 1200 ltr

ISO VG	China	U.S.		Britain	France
	GB11118.1	CALTEX CO.	MOBIL	SHELL	ELF CO.
HM 46	46 #	Rando HD46	D.T.E46	Tellus 46	Elfolna 46
HM 68	68 #	Rando HD68	D.T.E68	Tellus 68	Elfolna 68

Above information are indicative not engaging. Rights reserved for change if necessary.