

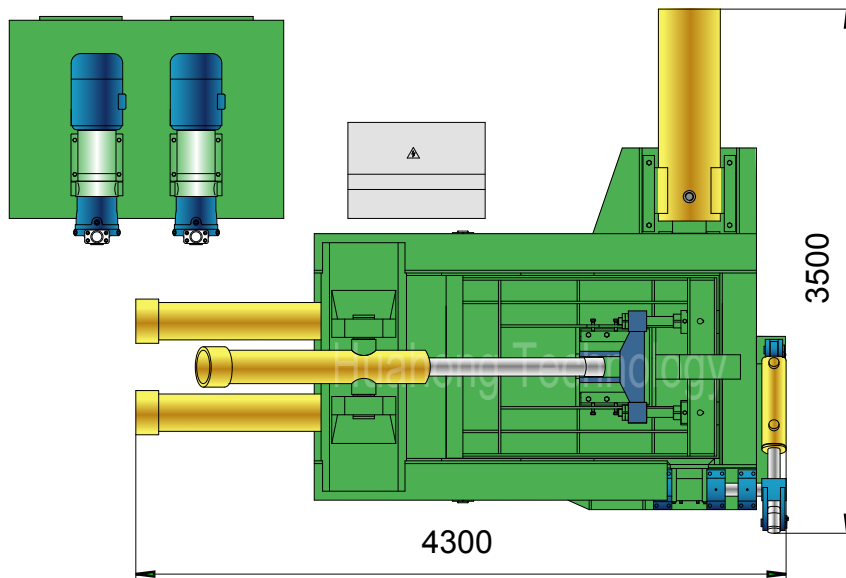

YE81F-160B

Plan View

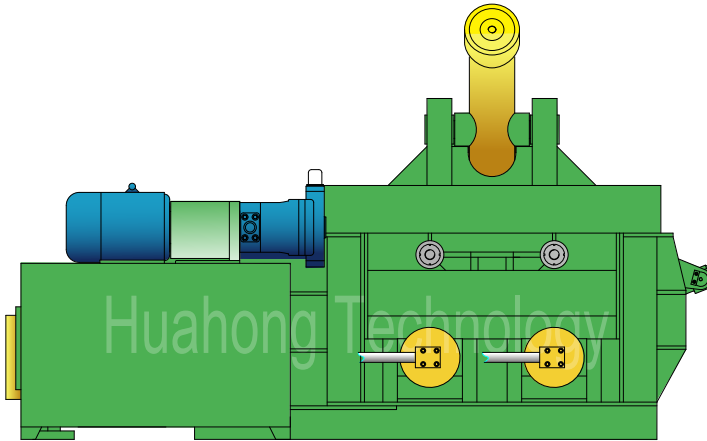

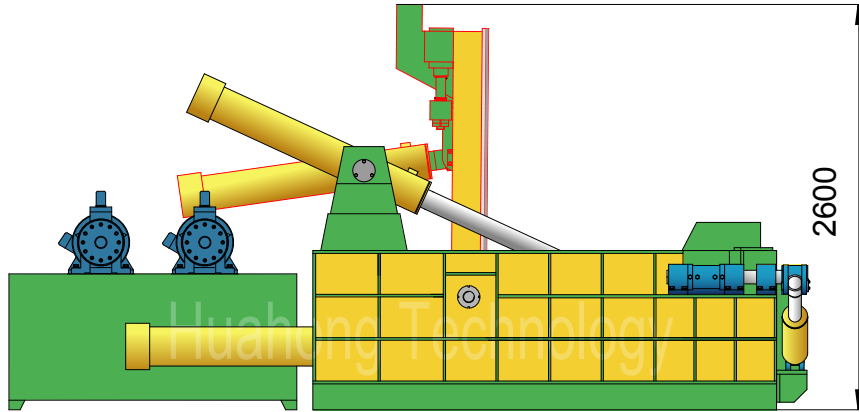

YE81F-160B

Technical parameters

"Turn-out" Type Metal Baler

Model: YE81F-160B

Power System (Motor)

Type:	Y225S-4
Rated Power:	37 kW
Rated Speed:	1480 rpm
Power Spec:	3PH, 50 / 60Hz

Hydraulic System (Pump)

Type:	HY125
Rated Displacement:	125 ml/r
Max Operating Pressure:	31.5 MPa

Standard Configuration

#45 Steel Liners 20mm, Wholly Heat Treated;
 NOK (JAPAN) Seal Packings for Cylinders;
 Cooler / Heater; Magnetic Oil Filter.

System Parameters

Lid Cyl. Force:	63 Ton
Side Pressure Cyl. Force:	2×80 Ton
Main Pressure Cyl. Force:	160 Ton
Bale Discharge Cyl. Force:	10 Ton
Hydraulic System Pressure:	25 MPa
Idle Cycle Time:	Approx. 100 Sec

Operation System

Manual Valve Operation

Optional Configuration

Cutting Blades & Teeth (2 sides);
 Mn65 Steel Liners for High Pressure Chamber;
 Diesel / Diesel Generator for Power.

General Description

Main Machine Size (L×W×H):	4300×3500×2600 mm
Press Box Size (L×W×H):	1600×1200×800 mm
Bale Size (W×H):	350×350 / 400×400 mm
Bale Weight (Steel):	100-200 kg
Production Rate (Steel):	2.0-4.0 tons/hr
Shipping Weight:	Approx. 13.8 tons
Loading (Standard Containers):	1×20'OT

Hydraulic Oil Brand

Oil Tank Volume: 1600 ltr

ISO VG	China	U.S.		Britain	France
	GB11118.1	CALTEX CO.	MOBIL	SHELL	ELF CO.
HM 46	46 #	Rando HD46	D.T.E46	Tellus 46	Elfolna 46
HM 68	68 #	Rando HD68	D.T.E68	Tellus 68	Elfolna 68

Above information are indicative not engaging. Rights reserved for change if necessary.