

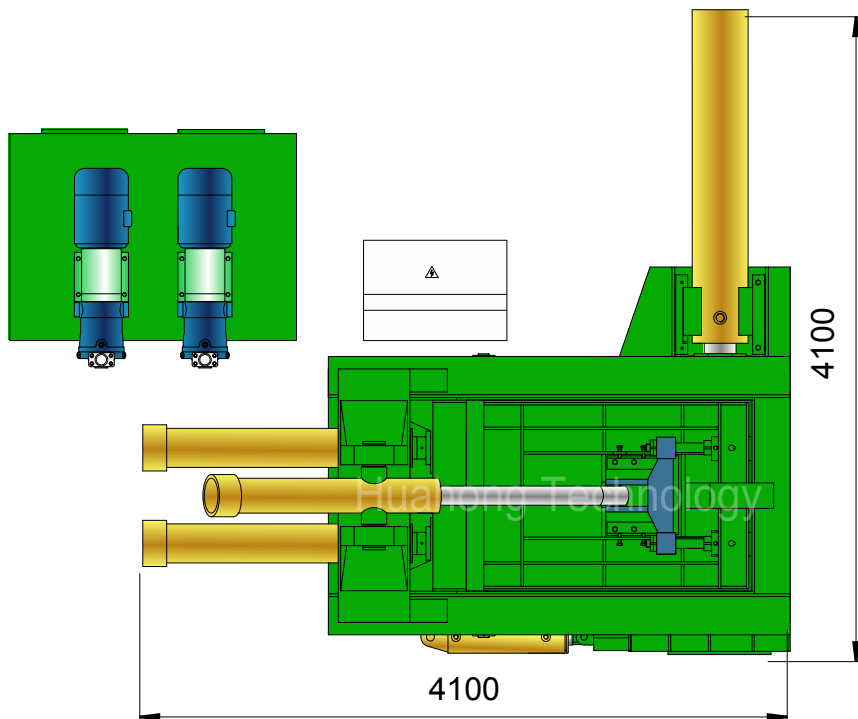

YE81T-160B

Plan View

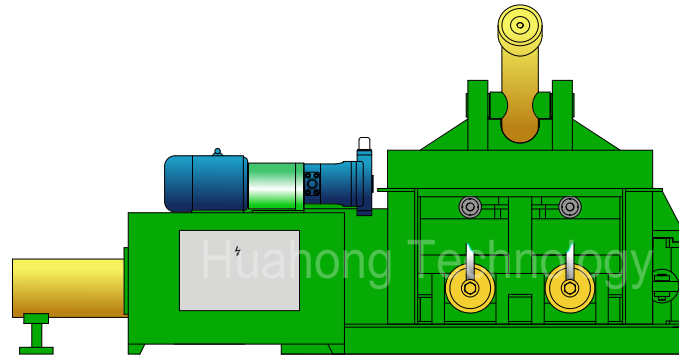

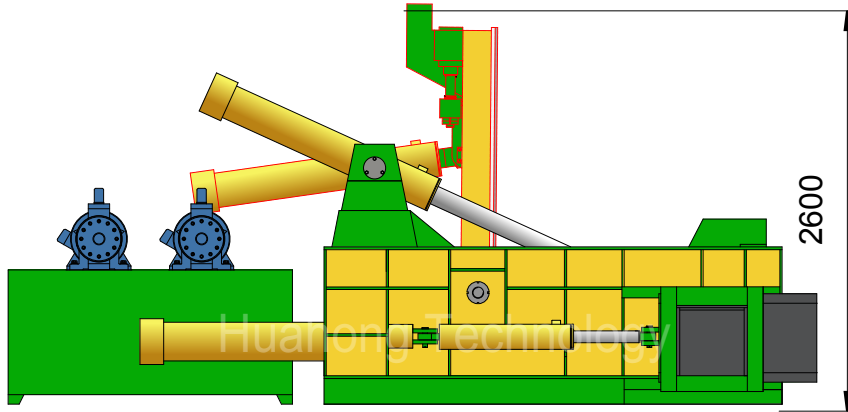

YE81T-160B

Technical parameters

"Push-out" Type Metal Baler

Model: YE81T-160B

Power System (Motor)

Type: Y280S-6
 Rated Power: 45 kW
 Rated Speed: 980 rpm
 Power Spec: 3PH, 50 / 60Hz

System Parameters

Lid Cyl. Force: 63 Ton
 Side Pressure Cyl. Force: 2×80 Ton
 Main Pressure Cyl. Force: 160 Ton
 Small Door Cyl. Force: 32 Ton
 Hydraulic System Pressure: 25 MPa
 Idle Cycle Time: Approx. 90 Sec

Hydraulic System (Pump)

Type: 250YCY14-1B
 Rated Displacement: 250 ml/r
 Max Operating Pressure: 31.5 MPa

Operation System (Optional)

Option 1: Manual Valve Operation
 Option 2: PLC Operation

Standard Configuration

#45 Steel Liners 20mm, Wholly Heat Treated;
 NOK (JAPAN) Seal Packings for Cylinders;
 Cooler / Heater; Magnetic Oil Filter.

Optional Configuration

Cutting Blades & Teeth (2 sides); Loading Hopper;
 Mn65 Steel Liners for High Pressure Chamber;
 Diesel / Diesel Generator for Power.

General Description

Main Machine Size (L×W×H): 4100×4100×2600 mm
 Press Box Size (L×W×H): 1600×1200×800 mm
 Bale Size (W×H): 350×350 / 400×400 mm
 Bale Weight (Steel): 100-200 kg
 Production Rate (Steel): 2.0-4.0 tons/hr
 Shipping Weight: Approx. 15 tons
 Loading (Standard Containers): 1×20'OT (Without Hopper)

Hydraulic Oil Brand

Oil Tank Volume: 1800 ltr

ISO VG	China	U.S.		Britain	France
	GB11118.1	CALTEX CO.	MOBIL	SHELL	ELF CO.
HM 46	46 #	Rando HD46	D.T.E46	Tellus 46	Elfolna 46
HM 68	68 #	Rando HD68	D.T.E68	Tellus 68	Elfolna 68

Above information are indicative not engaging. Rights reserved for change if necessary.