

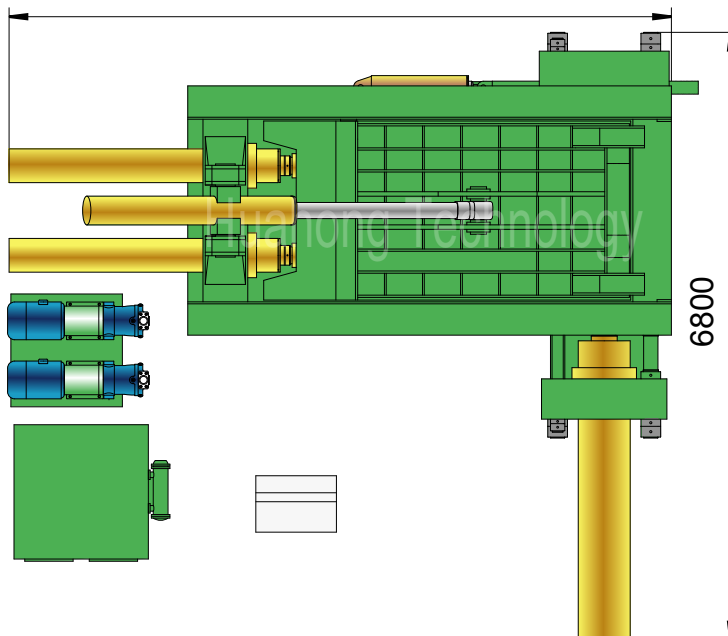

YE81T-315B

Plan View

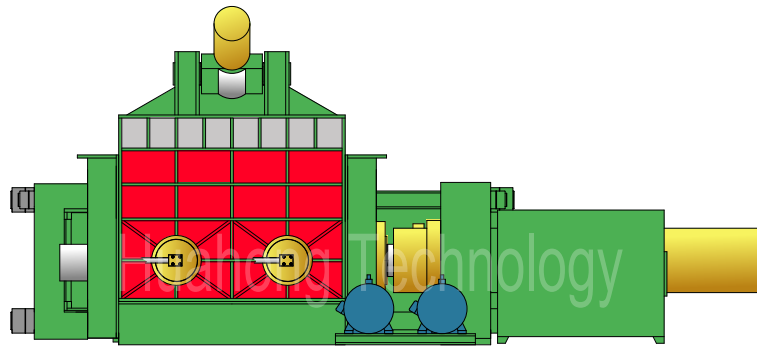

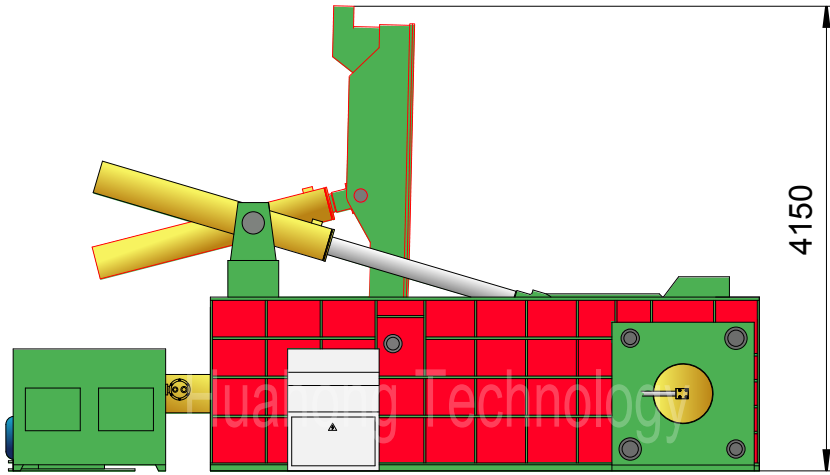

YE81T-315B

Technical parameters

"Push-out" Type Metal Baler

Model: YE81T-315B

Power System (Motor, 2 sets)

Type: Y280S-6
 Rated Power: 45 kW (/set)
 Rated Speed: 980 rpm
 Power Spec: 3PH, 50 / 60Hz

Hydraulic System (Pump, 2 sets)

Type: 250YCY14-1B
 Rated Displacement: 250 ml/r (/set)
 Max Operating Pressure: 31.5 MPa

Standard Configuration

#45 Steel Liners 20mm, Wholly Heat Treated;
 NOK (JAPAN) Seal Packings for Cylinders;
 Cooler / Heater; Magnetic Oil Filter.

System Parameters

Lid Cyl. Force: 100 Ton
 Side Pressure Cyl. Force: 2×160 Ton
 Main Pressure Cyl. Force: 315 Ton
 Small Door Cyl. Force: 63 Ton
 Locking Cyl. Force: 2×63 Ton
 Hydraulic System Pressure: 25 MPa
 Idle Cycle Time: Approx. 180 Sec

Operation System (Optional)

Option 1: Manual Valve Operation
 Option 2: PLC Operation

Optional Configuration

Cutting Blades & Teeth (2 sides); Loading Hopper;
 Mn65 Steel Liners for High Pressure Chamber;
 Diesel / Diesel Generator for Power.

General Description

Main Machine Size (L×W×H): 7050×6800×4150 mm
 Press Box Size (L×W×H): 2600×2000×1200 mm
 Bale Size (W×H): 500×600 mm
 Bale Weight (Steel): 400-700 kg
 Production Rate (Steel): 6.0-10.0 tons/hr
 Shipping Weight: Approx. 52 tons
 Loading (Standard Containers): 2×20'OT + 1×20'GP

Hydraulic Oil Brand

Oil Tank Volume: 2800 ltr

ISO VG	China	U.S.		Britain	France
	GB11118.1	CALTEX CO.	MOBIL	SHELL	ELF CO.
HM 46	46 #	Rando HD46	D.T.E46	Tellus 46	Elfolna 46
HM 68	68 #	Rando HD68	D.T.E68	Tellus 68	Elfolna 68

Above information are indicative not engaging. Rights reserved for change if necessary.