

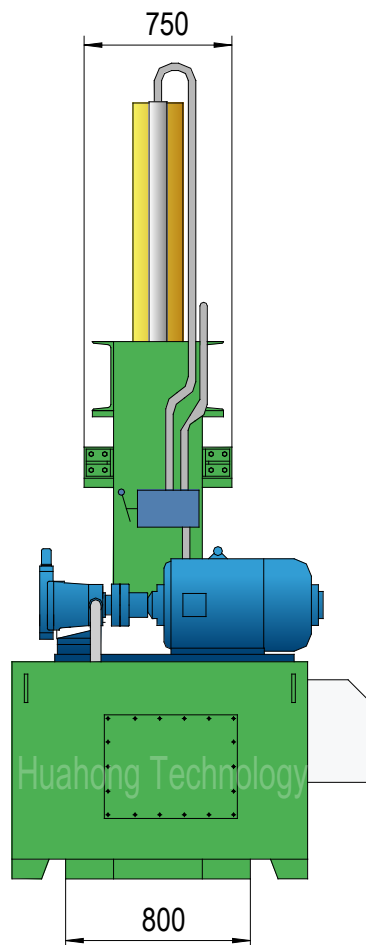

Y82-25YB

Plan View

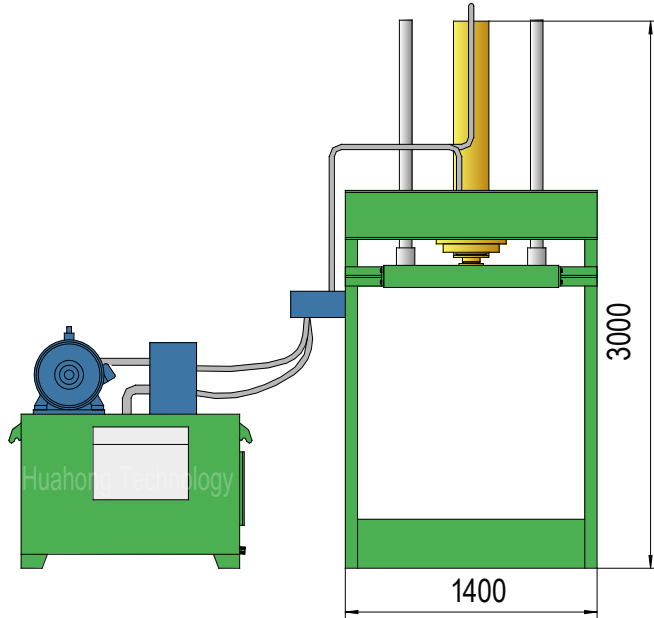



Y82-25YB

Technical parameters

Drum Flattener

Model: Y82-25YB

Power System (Motor)

Type: Y160L-6
 Rated Power: 11 kW
 Rated Speed: 970 rpm
 Power Spec: 3PH, 50 / 60Hz

System Parameters

Main Pressure Cyl. Force: 25 Ton
 Hydraulic System Pressure: 12.5 MPa

Hydraulic System (Pump)

Type: CBA1050
 Rated Displacement: 50 ml/r
 Max Operating Pressure: 21 MPa

Standard Configuration

NOK (JAPAN) Seal Packings for Cylinders.

Operation System

Manual Valve Operation

General Description

Main Machine Size (L×W×H): 1400×800×3000 mm
 Working Table Size (L×W): 1000×800 mm
 Pressure Ram Size (L×W): 960×750 mm
 Space Between Ram & Table: Max. 950 mm; Min. 50 mm
 Discharging: Manual Discharging
 Shipping Weight: Approx. 1.3 tons
 Loading (Standard Containers): 1/3×20'GP

Hydraulic Oil Brand

Oil Tank Volume: 320 ltr

ISO VG	China	U.S.		Britain	France
	GB11118.1	CALTEX CO.	MOBIL	SHELL	ELF CO.
HM 46	46 #	Rando HD46	D.T.E46	Tellus 46	Elfolna 46
HM 68	68 #	Rando HD68	D.T.E68	Tellus 68	Elfolna 68

Above information are indicative not engaging. Rights reserved for change if necessary.