

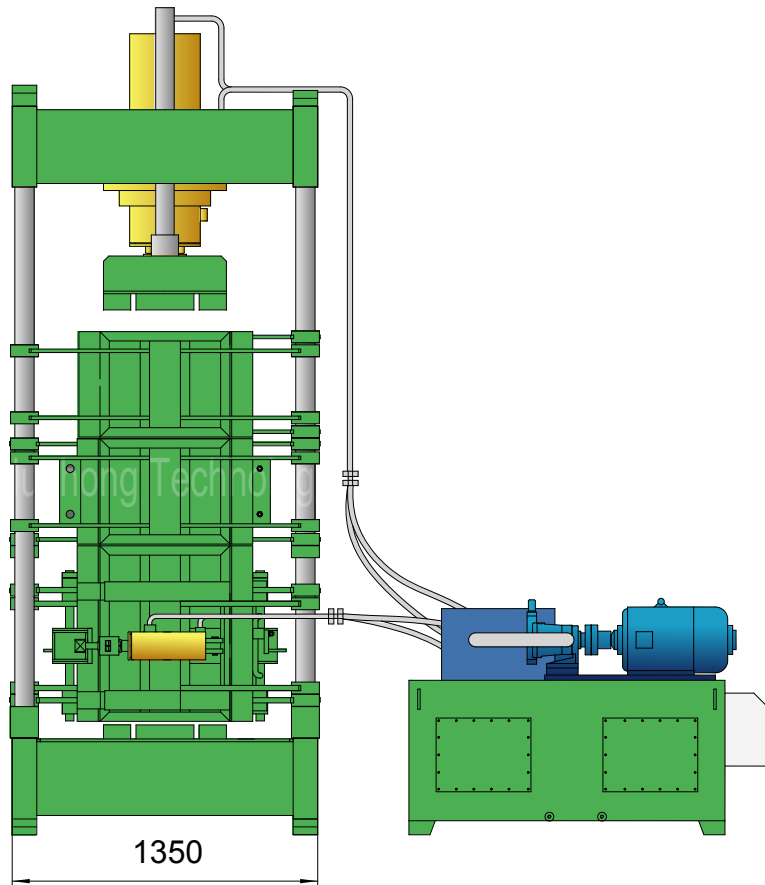

# Y82-63Q

## Plan View

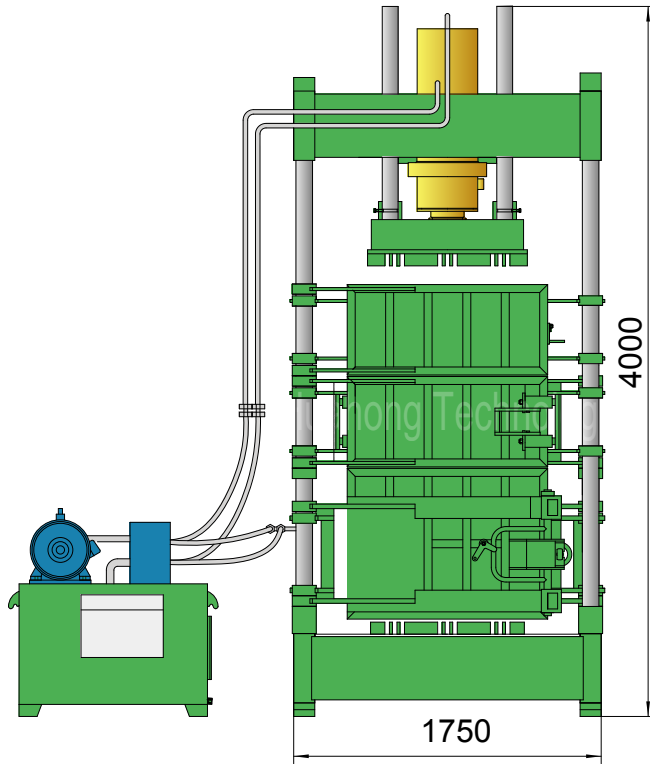



# Y82-63Q

## Technical parameters

### Wool Tops Baler

Model: Y82-63Q

### Power System (Motor)

Type: Y180L-6  
 Rated Power: 15 kW  
 Rated Speed: 970 rpm  
 Power Spec: 3PH, 50 / 60Hz

### System Parameters

Main Pressure Cyl. Force: 63 Ton  
 Hydraulic System Pressure: 20 MPa

### Hydraulic System (Pump)

Type: 63YCY14-1B  
 Rated Displacement: 63 ml/r  
 Max Operating Pressure: 31.5 MPa

### Standard Configuration

NOK (JAPAN) Seal Packings for Cylinders.

### Operation System

Manual Valve Operation

### General Description

Main Machine Size (L×W×H): 1750×1350×4000 mm  
 Press Box Size (L×W×H): 1080×740×1500 mm  
 Space Between Ram & Bottom: Max. 1600 mm; Min. 400 mm  
 Bale Size (L×W): 1080×740 mm  
 Wool Tops Nos. Per Bale: 18 or 24  
 Production Rate (Wool Tops): 6-8 bales/hr  
 Strapping: 5 Steel Strips, 2-way, Manual Strapping.  
 Bale Discharging: Manual Discharging  
 Shipping Weight: Approx. 4.2 tons  
 Loading (Standard Containers): 1×20'GP

### Hydraulic Oil Brand

Oil Tank Volume: 320 ltr

ISO VG	China	U.S.		Britain	France
	GB11118.1	CALTEX CO.	MOBIL	SHELL	ELF CO.
HM 46	46 #	Rando HD46	D.T.E46	Tellus 46	Elfolna 46
HM 68	68 #	Rando HD68	D.T.E68	Tellus 68	Elfolna 68

Above information are indicative not engaging. Rights reserved for change if necessary.