

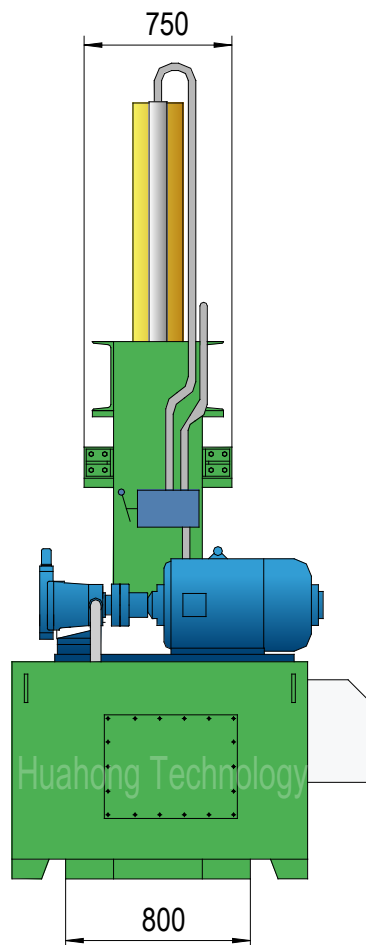

# Y82-63YB

## Plan View

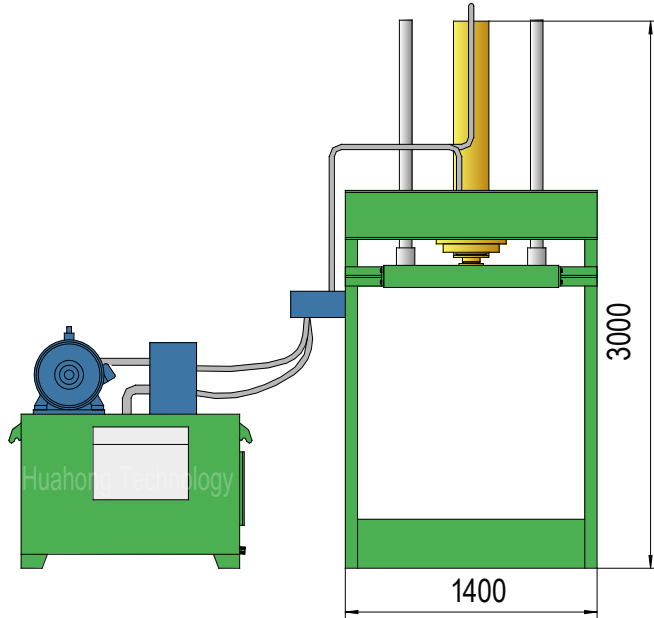



# Y82-63YB

## Technical parameters

### Drum Flattener

Model: Y82-63YB

### Power System (Motor)

Type:	Y180L-6
Rated Power:	15 kW
Rated Speed:	970 rpm
Power Spec:	3PH, 50 / 60Hz

### System Parameters

Main Pressure Cyl. Force:	63 Ton
Hydraulic System Pressure:	20 MPa

### Hydraulic System (Pump)

Type:	63YCY14-1B
Rated Displacement:	63 ml/r
Max Operating Pressure:	31.5 MPa

### Standard Configuration

NOK (JAPAN) Seal Packings for Cylinders.

### Operation System

Manual Valve Operation

### General Description

Main Machine Size (L×W×H):	1400×800×3000 mm
Working Table Size (L×W):	1000×800 mm
Pressure Ram Size (L×W):	960×750 mm
Space Between Ram & Table:	Max. 900 mm; Min. 100 mm
Discharging:	Manual Discharging
Shipping Weight:	Approx. 1.6 tons
Loading (Standard Containers):	1/3×20'GP

### Hydraulic Oil Brand

Oil Tank Volume: 320 ltr

ISO VG	China	U.S.		Britain	France
	GB11118.1	CALTEX CO.	MOBIL	SHELL	ELF CO.
HM 46	46 #	Rando HD46	D.T.E46	Tellus 46	Elfolna 46
HM 68	68 #	Rando HD68	D.T.E68	Tellus 68	Elfolna 68

Above information are indicative not engaging. Rights reserved for change if necessary.