

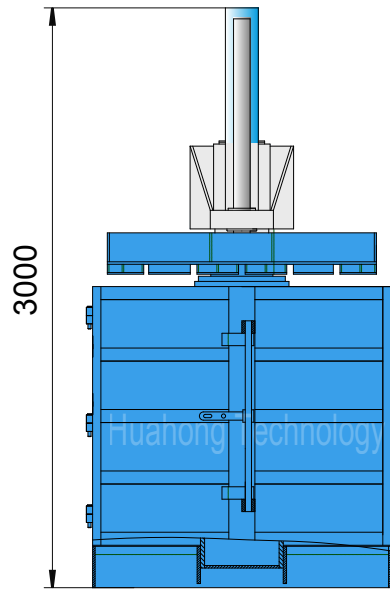

**YE82-12F**

Plan View

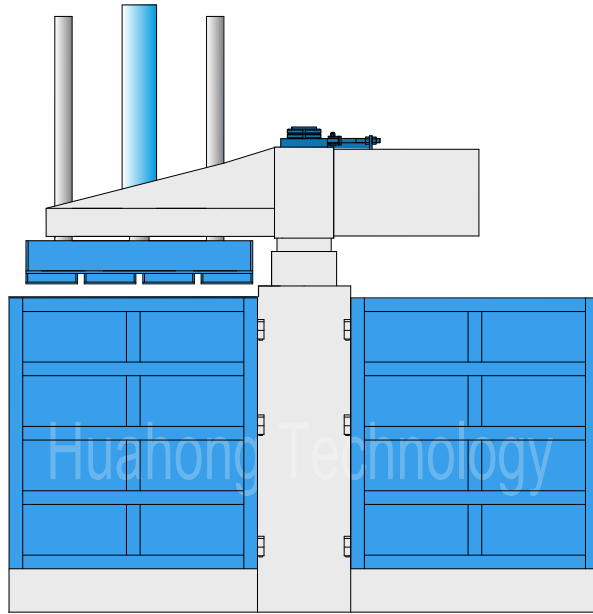

3000

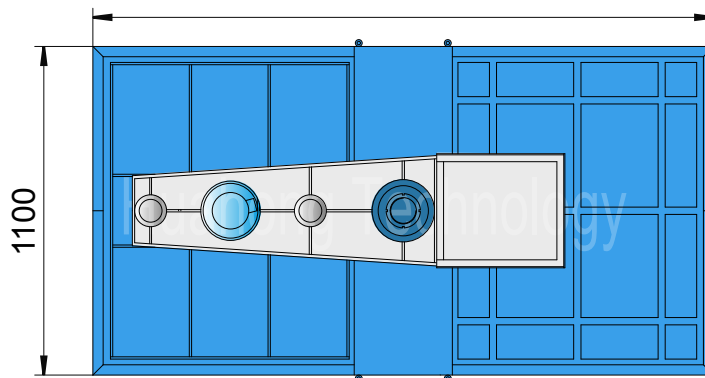

1100



# YE82-12F

## Technical parameters

Dual Chamber Paper / Plastic Baler

Model: YE82-12F

### Power System (Motor)

Type: Y112M-4  
 Rated Power: 4 kW  
 Rated Speed: 1440 rpm  
 Power Spec: 3PH, 50 / 60Hz

### System Parameters

Main Pressure Cyl. Force: 12 Ton  
 Hydraulic System Pressure: 9.5 MPa

### Hydraulic System (Pump)

Type: PV2R1-17  
 Rated Displacement: 17.1 ml/r  
 Max Operating Pressure: 21 MPa

### Standard Configuration

NOK (JAPAN) Seal Packings for Cylinders.

### Operation System

Hydro-electrical Valves, Push Button Control.

### General Description

Main Machine Size (L×W×H): 3000×1100×3000 mm  
 Press Box Size (L×W×H): 1200×900×1170 mm (Dual Chamber)  
 Space Between Ram & Bottom: Max. 1250 mm; Min. 350 mm  
 Bale Size (L×W): 1200×900 mm  
 Bale Weight (Cardboard): 150-200 kg  
 Production Rate (Cardboard): 900-1200 kg/hr  
 Strapping: Tempered Iron Wire, φ2.8/3.2mm, 8 Lines 2-way, Manual Strapping.  
 Bale Discharging: Manual Discharging  
 Shipping Weight: Approx. 3.5 tons  
 Loading (Standard Containers): 1/2×20'GP

### Hydraulic Oil Brand

Oil Tank Volume: 120 ltr

ISO VG	China	U.S.		Britain	France
	GB11118.1	CALTEX CO.	MOBIL	SHELL	ELF CO.
HM 46	46 #	Rando HD46	D.T.E46	Tellus 46	Elfolna 46
HM 68	68 #	Rando HD68	D.T.E68	Tellus 68	Elfolna 68

Above information are indicative not engaging. Rights reserved for change if necessary.