

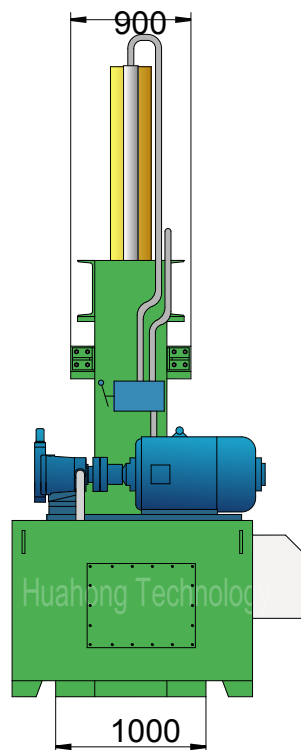

YE82-63B

Plan View

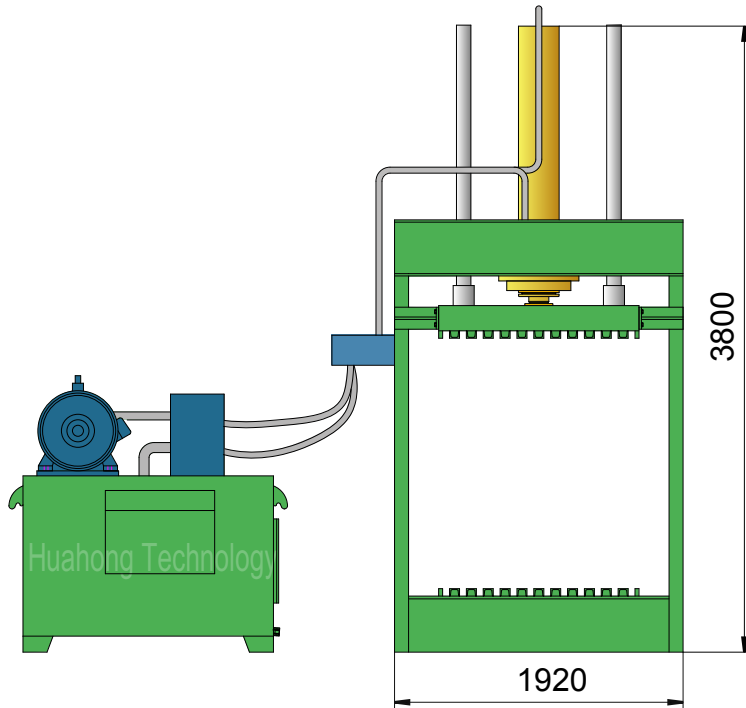



YE82-63B

Technical parameters

Cloth / Woven Bags / Sacks Baler

Model: YE82-63B

Power System (Motor)

Type: Y180L-6
 Rated Power: 15 kW
 Rated Speed: 970 rpm
 Power Spec: 3PH, 50 / 60Hz

System Parameters

Main Pressure Cyl. Force: 63 Ton
 Hydraulic System Pressure: 20 MPa

Hydraulic System (Pump)

Type: 63YCY14-1B
 Rated Displacement: 63 ml/r
 Max Operating Pressure: 31.5 MPa

Standard Configuration

NOK (JAPAN) Seal Packings for Cylinders.

Operation System

Manual Valve Operation

General Description

Main Machine Size (L×W×H): 1920×1000×3800 mm
 Working Table Size (L×W): 1600×1000 mm
 Pressure Ram Size (L×W): 1350×900 mm
 Space Between Ram & Table: Max. 1400 mm; Min. 200 mm
 Strapping: Tempered Iron Wire, φ2.8/3.2mm, Manual Strapping.
 Bale Discharging: Manual Discharging
 Shipping Weight: Approx. 3.7 tons
 Loading (Standard Containers): 1/2×20'GP

Hydraulic Oil Brand

Oil Tank Volume: 320 ltr

ISO VG	China	U.S.		Britain	France
	GB11118.1	CALTEX CO.	MOBIL	SHELL	ELF CO.
HM 46	46 #	Rando HD46	D.T.E46	Tellus 46	Elfolna 46
HM 68	68 #	Rando HD68	D.T.E68	Tellus 68	Elfolna 68

Above information are indicative not engaging. Rights reserved for change if necessary.