

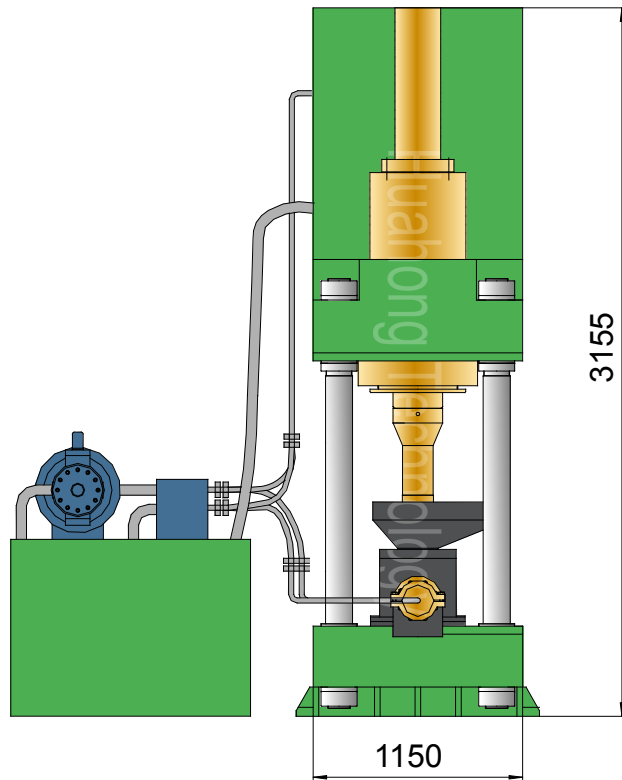

Y83-315

Plan View

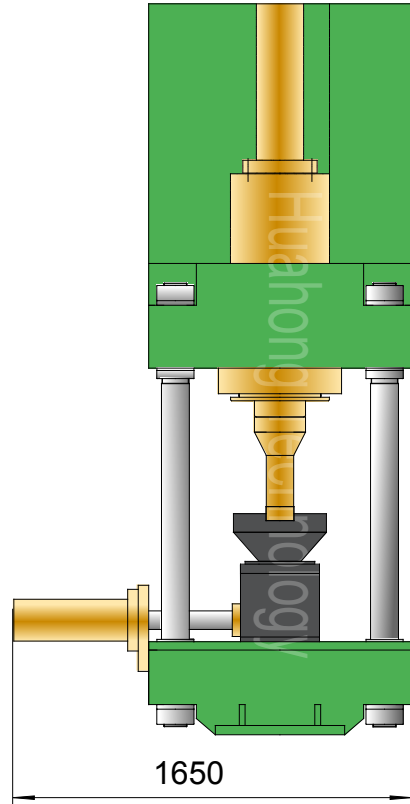



Y83-315

Technical parameters

Scrap Briquetting Press

Model: Y83-315

Power System (Motor)

Type: Y200L2-6
 Rated Power: 22 kW
 Rated Speed: 970 rpm
 Power Spec: 3PH, 50 / 60Hz

System Parameters

Main Cyl. Force: 285 Ton
 Auxiliary Cyl. Force: 55 Ton
 Discharging Cyl. Force: 30 Ton
 Hydraulic System Pressure: 25 MPa
 Idle Cycle Time: 10-12 Sec

Hydraulic System (Pump)

Pump #1: 160YCY14-1B
 Rated Displacement: 160 ml/r
 Max Operating Pressure: 31.5 MPa

Operation System

PLC Operation

Pump #2: 63YCY14-1B
 Rated Displacement: 63 ml/r
 Max Operating Pressure: 31.5 MPa

Optional Configuration

Cooler / Heater;
 Feeding Conveyor & Vibrating Motor;
 Diesel / Diesel Generator for Power.

General Description

Main Machine Size (L×W×H): 1650×1150×3155 mm
 Press Mould Size (Dia×H): Φ 120×180 / Φ 140×180 mm
 Pressure on Briquet: 278 / 204 MPa
 Briquet Size (Dia×H): Φ 120×(50-70) / Φ 140×(50-70) mm
 Briquet Weight (Cast Iron): 3.1-4.5 / 3.6-5.1 kg
 Production Rate (Cast Iron): 900-1100 kg/hr
 Shipping Weight: Approx. 8 tons
 Loading (Standard Containers):

Hydraulic Oil Brand

Oil Tank Volume: 2500 ltr

ISO VG	China	U.S.		Britain	France
	GB11118.1	CALTEX CO.	MOBIL	SHELL	ELF CO.
HM 46	46 #	Rando HD46	D.T.E46	Tellus 46	Elfolna 46
HM 68	68 #	Rando HD68	D.T.E68	Tellus 68	Elfolna 68

Above information are indicative not engaging. Rights reserved for change if necessary.